

# **Firewood boiler**

## **Vedolux 40 UB**

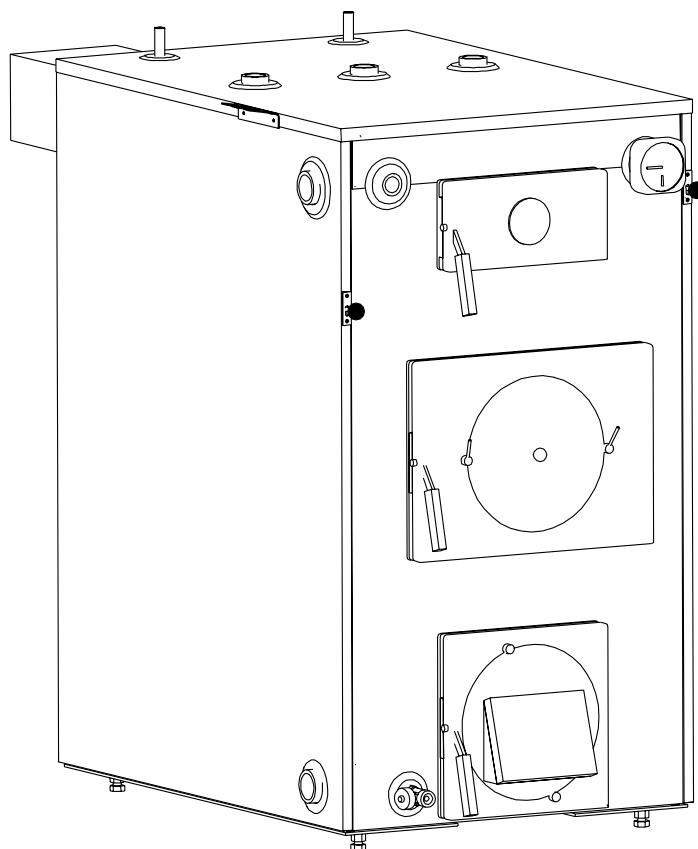

## To be completed when the Vedolux 40 UB is installed

Serial number: .....

Installation date: .....

Installer: .....

Tel: .....

Accumulator volume: .....

Accumulator control: .....

Other: .....

.....

.....

.....

.....

.....

<b>General</b> .....	<b>3</b>	<b>Commissioning and checks</b> .....	<b>8</b>
<b>Operation</b> .....	<b>4</b>	General	
<b>Technical data</b> .....	<b>5</b>	Checks	
<b>Installation</b> .....	<b>6</b>	Operation and care	
General		Filling/bleeding	
Location		Safety valves	
Chimney		Closed expansion system	
Ventilation		Cleaning	
Flue pipe		Cleaning the boiler	
Expansion system		<b>Operation and care</b> .....	<b>9</b>
Vented		Ceramic	
Unvented		Inner ash hatch	
Cooling coil - temperature limiter		Bypass damper	
High temperature hot water outlet		Flue gas damper	
Circulation pump - radiator system		Controlling combustion	
Filling/draining		If there is a risk of freezing	
Shunt		Draining the boiler	
Flue gas thermometer		Boiler cleaning	
Bracket for cleaning tool		Using electricity and firewood in combination	
Turbulators		<b>Firewood as a fuel</b> .....	<b>10</b>
Pellet burner		Firewood as a fuel	
<b>Installation</b> .....	<b>7</b>	Firewood	
System principle		Heat content	
Connection to accumulator system		First burning cycle	
Function of accumulator control		Lighting a fire with the gas lighter	
Return temperature to boiler		Lighting a fire without the gas lighter	
Hatches		Adding wood	
		<b>Problems burning firewood</b> .....	<b>11</b>
		<b>Component specification</b> .....	<b>12</b>

## General

***Read this document carefully before carrying out any installation, adjustment or service – and follow the instructions.***

- **Keep these instructions close to the boiler!**
- **The boiler must not be modified, changed or rebuilt.**
- **To guarantee high reliability, all installation, adjustment and ongoing service must be carried out correctly.**
- **The correct settings are important for economical heating.**
- **The type and serial number of the boiler must be quoted whenever you contact your retailer, see the rating plate.**
- **For service issues, contact your installer.**
- **Värmebaronen AB retains the right to change the specification without prior notice, as part of its policy of continuous improvement and development.**

These instructions use the following icons to identify important information:



Information that is important for optimum function.



Tells you what you must – or must not – do in order to avoid personal injury.



Tells you what you must – or must not – do in order to prevent damage or disturbance to the component, the burner, the process or the surroundings.

### COMBINING FUELS

The Vedolux 40 UB is primarily a ceramic firewood boiler, but a combination of two fuels can also be used, either firewood/pellets or firewood/electricity.

If used with electricity, the immersion heaters are installed in the accumulator tank with water heater.

### CERAMIC COMBUSTION CHAMBER

The combustion chamber is designed for reverse combustion, with a ceramic grate and a ceramic afterburning chamber.

The depth of the combustion chamber is 575 mm. A bypass damper makes the boiler easier to start and prevents smoke entering the room when firewood is added.

### AIRTIGHT COMBUSTION CHAMBER HATCHES

The combustion chamber hatches are made of cast iron, and are polished flat to maintain high efficiency.

### EFFICIENCY CLEANING

All flue gas ducts are cleaned from the same hatch at the front of the boiler. The hatch is hinged and is opened with a single operation. The flue gas ducts are round, which means there are no awkward corners when flue cleaning.

### CHIMNEY

For burning firewood, it is important for the chimney to have sufficient height and cross sectional area. If the chimney does not come up to standard, a chimney fan can be installed to compensate.

### ACCUMULATOR TANK

To optimise combustion and efficiency, and to meet environmental requirements relating to firewood burning, the boiler must be connected to an accumulator tank. The accumulator volume is dimensioned according to the surface area to be heated – allow for 8 - 10 litres of tank volume per square metre of heated surface area.

### DELIVERY

The product is delivered with the following components:

- Flue pipe.
- Flue cleaning tool with bracket.
- Flue gas thermometer.
- Drain valve.
- Gas lighter.

### ACCESSORIES

- Base frame to make firewood burning more convenient.
- Ackstyrning 3 accumulator control.
- Turbulators.
- Flue pipe pointing up.

<b>Weight</b>	empty	350 kg	<b>Max operating temperature</b>	100°C	<b>Chimney requirement</b>	height	7 m
	filled with water	483 kg		<b>Power</b>		pellet	25-50 kW
<b>Volume</b>		133 litres		firewood	35*/40** kW		1 x ½ brick
<b>Design pressure</b>		1.5 bar	<b>Combustion chamber</b>	volume	120 litre	tube	Ø180 mm
<b>Test pressure</b>		2.15 bar		depth	575 mm	draught	20 Pa
<b>Design temp</b>		100°C					2.0 mmwc

\*Nominal power (average power over 2 hours).

\*\* Max power.

Nominal and maximum power measured with a draught of 2 mmwc and a moisture content of 18% ±2%

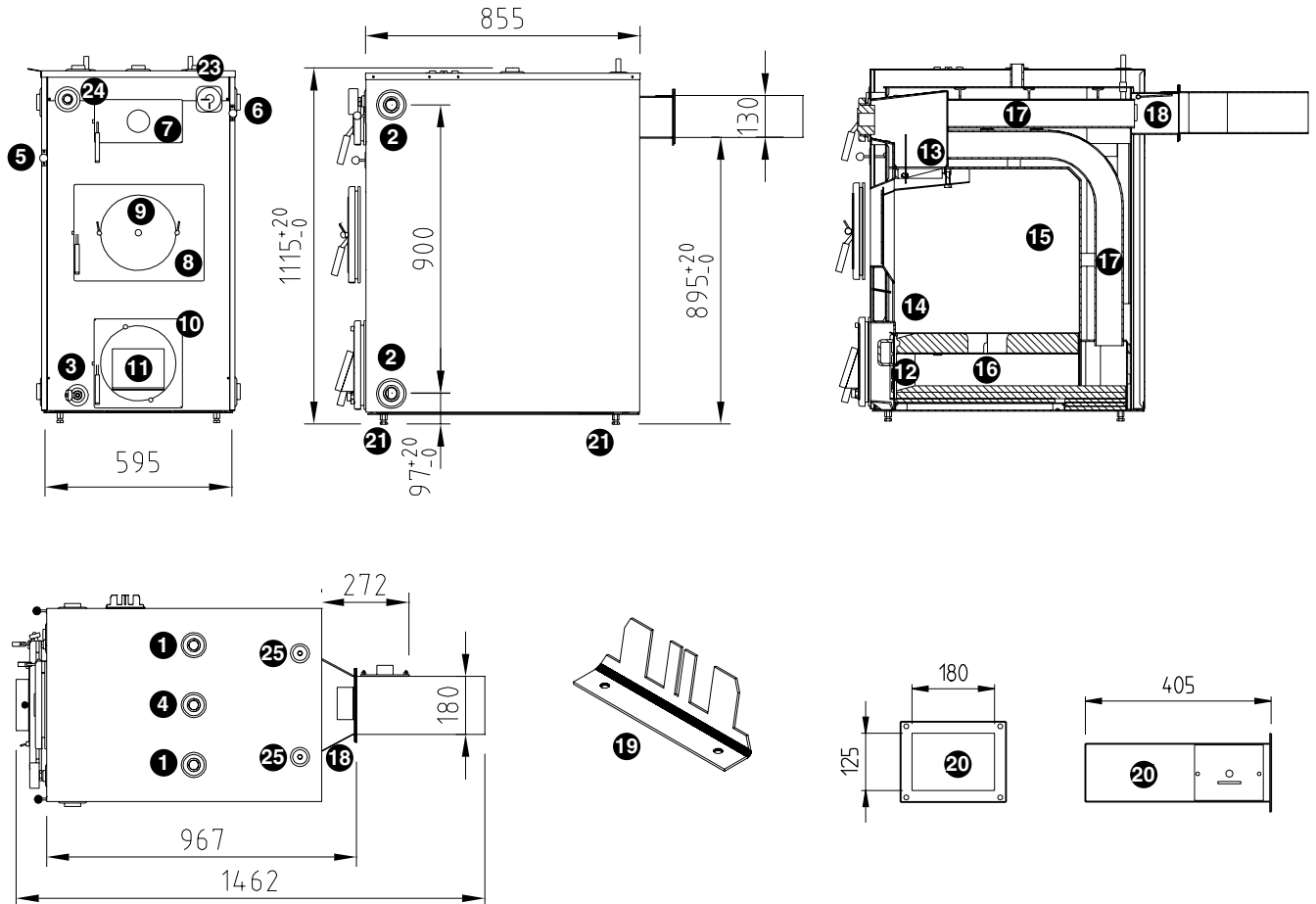

1. Expansion pipe R25 int.
2. High temperature hot water outlet, R32 int, on both sides of boiler.
3. Drain valve.
4. Lifting attachment, expansion/safety pipe R25 int.
5. Control for bypass damper.
6. Control for flue gas damper.
7. Cleaning hatch.
8. Firewood hatch.
9. Cover for pellet burner connection.
10. Ash hatch.
11. Draught hatch.
12. Inner ash hatch with secondary damper.
13. Bypass damper.
14. Primary air duct.
15. Combustion chamber.
16. Ceramic.
17. Flue gas ducts 3 x Ø 80 mm.
18. Flue pipe connection.
19. Bracket for cleaning tool.
20. Flue pipe back, pointing backwards, with cleaning hatch.
21. Adjustable base bolts.
23. Temperature sensor and pressure gauge.
24. Attachment R20 int.
25. Cooling coil, compression ring Ø 15 mm.

## General

Boiler installation must be carried out in accordance with FS 2006:12, BBR 12 and the Hot Water Instructions [Holvatteningarna].

You must contact the chimney sweep before changing fuel.

Contact the municipality to find out about restrictions on the use of solid fuels in built-up areas.

The boiler must be installed indoors in a cellar or on the ground floor.

The installation site must be able to support the combined weight of the boiler and the accumulator tanks.

A temperature limiter must always be installed with the boiler.

The boiler must be connected to an accumulator tank, and the installation must include an accumulator control.

## Location

The location of the boiler and tanks and the dimensions of the pipes must allow for natural circulation between the boiler and the tanks, with limited power output from the boiler. If the boiler and tanks are positioned next to each other, 28 or 35 mm Cu pipe is recommended. Adjust the base bolts to make the boiler level.

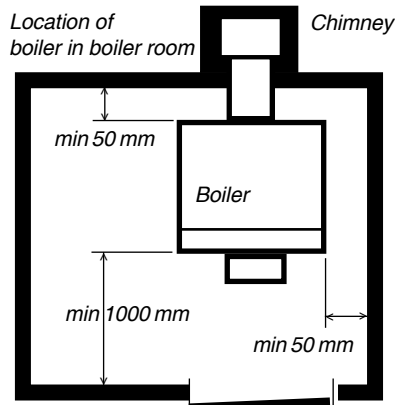

## Chimney

The chimney must produce a draught with a 20 Pa pressure difference. The draught depends on the chimney height – in theory, every metre of chimney produces 3 Pa.

The flue duct must be less than Ø180 mm or 1 x ½ bricks. If the boiler is connected to the chimney higher up than the previous boiler, the lower, unused, part must be filled, for example with sand.

It must be possible to clean the chimney in accordance with the applicable rules – contact the chimney sweep if you are not sure.

## Flue pipe

The boiler is supplied with the flue pipe pointing backwards. Flue pipes pointing up are available as accessories.

## Ventilation

The fresh air intake of the boiler room must have at least the same cross sectional area as the chimney, and it must be designed so it is impossible to close it by mistake.

## Expansion system

The boiler must be connected to a vented or unvented expansion system.

The volume of the expansion vessel is dimensioned according to the circumstances. The guideline values for volume are approx. 5 % of the total system volume for vented systems, or 13- 15 % for unvented systems.

**Vented:** The distance between the top of the highest radiator and the expansion vessel must be at least 2.5 metres in order to prevent oxygen saturation of the water in the heating system. The expansion vessel is connected in a continuous and unisolatable rise from the boiler's expansion connection.

**To prevent damage occurring if the expansion system fails, for example because of freezing, the boiler should be fitted with a type approved safety valve, 1.5 bar.**

**Unvented:** In unvented systems, the boiler must be fitted with a type approved safety valve, 1.5 bar, connected using an unisolatable pipe from the connection at the top of the boiler, as well as a bleed valve.

The expansion vessel is best connected using 15 mm Cu pipe, as shown in the system principle. Overflow pipes from the safety valve must be laid to a floor drain so that no splashes of hot water can occur when the valves are checked or the boiler is vented. The opening of the overflow pipe must be visible.



### SAFETY VALVE 1.5 bar

**In a closed expansion system, the boiler system must be fitted with a safety valve with an opening pressure of 1.5 bar.**

## Cooling coil - temperature limiter

The boiler has a cooling coil which, combined with a suitable thermal valve, is used to prevent the boiler temperature exceeding 110°C if the water boils. Follow the instructions of the valve manufacturer.

## High temperature hot water outlet

The Vedolux 40 UB has high temperature hot water outlets on both sides of the boiler.

## Circulation pump - radiator system

The radiator pump is dimensioned according to the size, pipe dimensions and design of the system. If the pump capacity is too high, the stratification in the accumulator tank may be impaired.

## Filling/draining

The best way to fill with water is to use a permanent filling pipe or a hose to the drain valve.

To drain the system, connect a hose to the drain valve on the boiler.

## Shunt

The Vedolux 40 UB is supplied without a shunt. In Värmebaronen systems, the shunt is fitted to the accumulator tank with water heater.

You are recommended to equip the shunt with a system for automatic shunt control. The benefits of automatic shunt control include constant temperatures in the building, the option of night-time temperature reduction, better use of the accumulated heat, etc.

## Flue gas thermometer

Install the flue gas thermometer in the connection on the flue pipe.

## Bracket for cleaning tool

You are recommended to fit the bracket for the cleaning tool to the side of the boiler or to a wall close to the boiler.

## Turbulators

Flue gas turbulators are available as accessories, and can be used if a good chimney provides a good draught, resulting in a high flue gas temperature.

The turbulators can be cut as a way of adjusting the flue gas temperature.

## Pellet burner

The Vedolux 40 UB is primarily designed to be fired by firewood, but can also be modified for pellets using a pellet burner.

The burner is attached to the firewood hatch.

The ceramic grate must remain in the boiler.

Fit an operating thermostat with overheating thermostat to one of



**System principle - the actual system will be designed according to the applicable standards and the instructions supplied with each component.**

**Vedolux 40 UB**

**Aqualux CU and Aqualux UB**

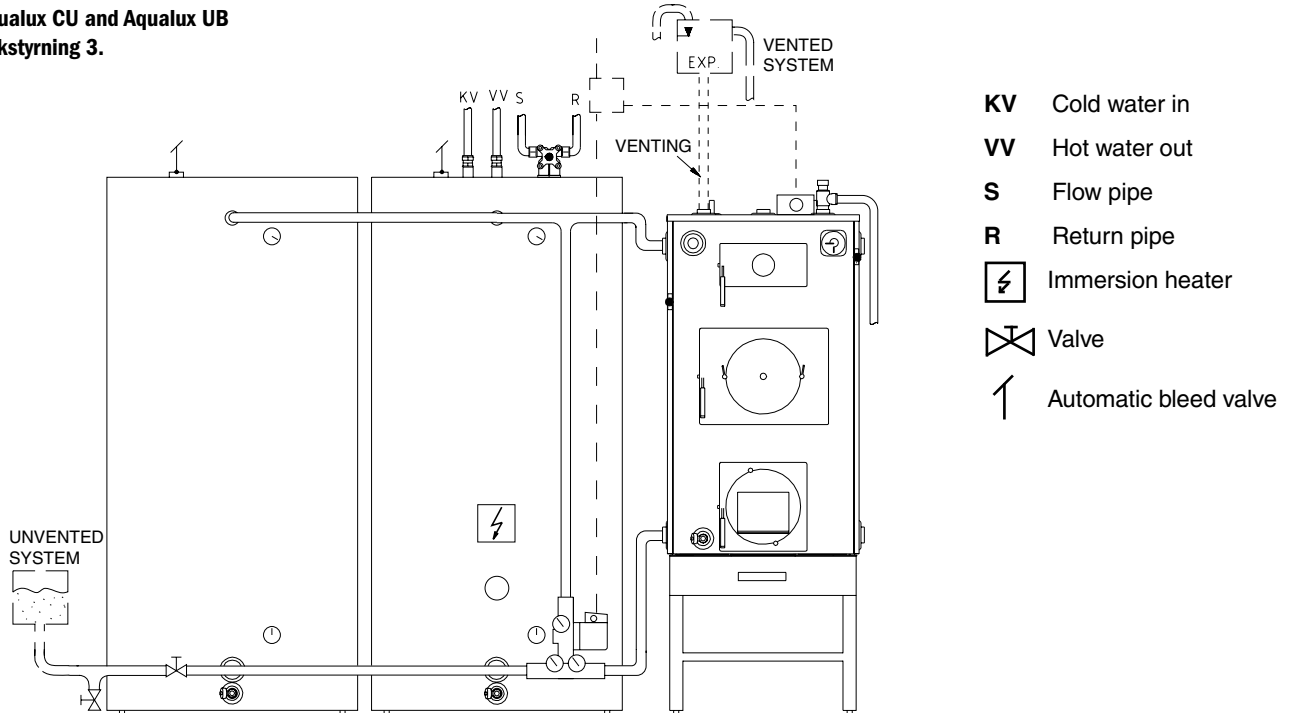
**Ackstyrning 3.**



- KV** Cold water in
- VV** Hot water out
- S** Flow pipe
- R** Return pipe
-  Immersion heater
-  Valve
-  Automatic bleed valve

the high temperature hot water outlets, or just the overheating protection if you are using the temperature control in the Viking Bio pellet burner.

Because of the risk of condensation you should monitor the flue gas temperature. Check that the flue gas temperature is appropriate for the chimney type.

You can open the bypass damper as a way of adjusting the flue gas temperature, but no more than a few centimetres.

A draught regulator must be installed in the chimney.

The draught hatch on the boiler must be closed and sealed.

A correctly adjusted burner generates low flue gas emissions and is highly efficient – the adjustment must be carried out by an expert.

Otherwise, follow the installation instructions of the burner manufacturer.

### Connection to accumulator system

The boiler must always be connected to an accumulator tank with an accumulator control.

The accumulator volume is dimensioned according to the surface area to be heated – allow for 8 - 10 litres of tank volume per square metre of heated surface area.

The system principle shows the Vedolux 50 UB with Aqualux CU and Aqualux UB accumulator tanks, and Ackstyrning 3. For more details, see the documentation supplied with the relevant product.

The pipe dimension between the boiler and the tank should be 28/35 mm for copper pipe or equivalent.

### Function of the accumulator control

The purpose of the accumulator control is to:

- ensure that the boiler reaches a high working temperature before it starts charging the accumulator tank,
- to prevent the return temperature to the boiler falling too low, helping to minimise the risk of condensation in the combustion chamber,
- to create pronounced thermal stratification in the tank

The charging pump of the accumulator system is controlled by a flue gas thermostat, and starts when the flue gas temperature reaches the set value. Hot water from the top of the boiler starts circulating through the accumulator control, and back to the return connection on the boiler.

When the boiler temperature reaches around 70°C, some of the hot water from the top of the boiler is circulated to the top of the accumulator. Cold water is taken from the bottom of the accumulator and is circulated to the accumulator control, where it is mixed with hot water from the top of the boiler to prevent the return temperature to the boiler falling below 72°C. To prevent the accumulator water cooling down unnecessarily, the flue gas thermostat stops the charging pump when the flue gas temperature falls below the specified value on the flue gas thermometer.

A non-return valve in the accumulator control prevents unwanted natural circulation when the charging pump is not running.

### Return temperature to boiler

For a longer boiler service life, it is important for the return temperature to the boiler from the accumulator tank not to fall below 60°C. This is to prevent condensation occurring in the boiler combustion chamber, with the resulting risk of corrosion.

### Hatches

The hatches are supplied hinged on the right, but they can be turned so they are hinged on the left.

To change a hatch around, loosen the hatch frame from the boiler and rotate it 180°.

Rotate the handle and the draught hatch on the ash hatch. A new combustion plate, "misshapen 832475", must be added to the firewood hatch. Contact Värmebaronen.

### General

Ask the installer to demonstrate the settings and functions so you know how to operate and care for the system.

### Checks

Before putting the system into operation, check that:

- the system is filled with water.
- all connections are watertight.
- flue gas connections to the boiler and to the chimney are tight.
- the filling/drain valve has been closed properly.
- the safety valves are working correctly.
- the circulation pumps are working and the direction of flow is correct.
- the necessary valves are open.
- the correct temperature has been set on the charge thermostat.

## Operation and care

### Filling/bleeding

Regularly check that there is sufficient water in the heating system.

Air may remain in the system for a while after installation, so bleeding should be repeated a few times. After bleeding, check the pressure and add water if necessary.

The pressure required in the heating system depends on the height difference between the highest and lowest points in the system, the static head. If the height difference is 5 metres, the pressure is 0.5 bar, if it is 10 metres, the pressure is 1 bar.

The volume of water changes with the temperature, and the change in volume affects the pressure in the system. The higher the temperature the greater the volume and the higher the pressure. The expansion vessel takes up the changes in volume. The flow temperature – and therefore also the pressure – is higher in the summer than the winter.

**The pressure in the system varies with the boiler temperature – do not add water unnecessarily.**

### Safety valves

In order to preserve the safety function, the safety valves for the domestic hot water system and the heating system must be operated regularly, around four times a year.

Open and close the safety valve manually around four times a year. Check that a small amount of water escapes and that the valves then return to a tight seal.

Also check that there is sufficient pressure in the system. If necessary, add more water.

### Unvented expansion system

The pressure in the unvented expansion vessel should be checked at intervals of several years. Contact your installer.

### Cleaning



**Risk of burns.**

**Leave the fire to die out and the boiler to cool down before cleaning.**

The Rescue Services Act ("Räddningstjänstlagen") lays down how often the boiler must be cleaned and the period between cleaning. The cleaning to be carried out by the chimney-sweep includes all the flue gas paths.

In a cleaned boiler, less of the heat escapes with the flue gases. One way of telling whether it is time for cleaning is to check the flue gas thermostat. Clean the boiler if the temperature is approx. 25°C higher than the temperature in a recently cleaned boiler.

You should carry out efficiency cleaning at short intervals, by opening the cleaning hatch and cleaning the pipes with the pipe brush supplied.

It is normal for tar to form on the walls of the combustion chamber and it does not need to be removed. It will burn off once the layer has reached a certain thickness. The tar does not affect the efficiency of the boiler, and the output of the boiler is dimensioned on the basis of the heat conversion surface area in the flue pipes, which must be cleaned regularly.

### Cleaning the boiler

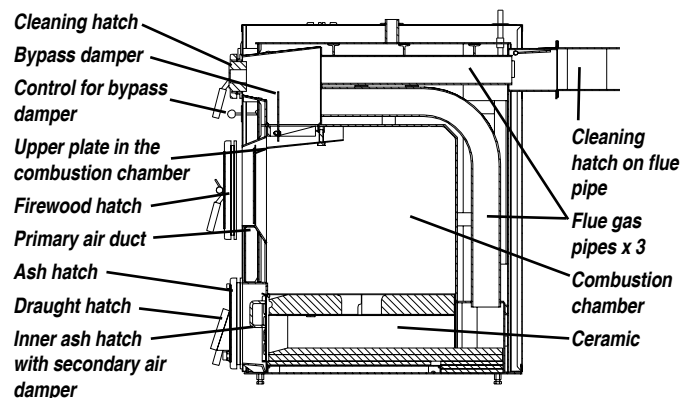

- Open the cleaning hatch. Clean the pipes with the pipe brush. When cleaning the three upper pipes, be careful not to damage the flue gas thermometer with the pipe cleaner. Close the cleaning hatch.
- Open the firewood hatch and bypass damper. Remove the ash on the upper plate in the combustion chamber. Scrape the ceramic gently and carefully when removing ash. Always leave a layer of ash couple of centimetres thick on the ceramic grate. Pieces of charcoal from the previous burning cycle can be left for the next cycle. Close the firewood hatch.
- Open the ash hatch and remove the inner ash hatch. Gently and carefully scrape out the ash from the ceramic tunnel. The ash should be removed from the combustion tunnel before each burning cycle.
- Close all hatches and dampers.



**Ashes may contain embers for a long time after the burning cycle, so keep them in a non-flammable container with a cover.**



## Ceramic

The ceramic parts in the boiler are wearing parts that will have to be replaced over time. Wearing parts are not covered by any guarantee. Small cracks in the ceramic are not abnormal and no action is necessary.

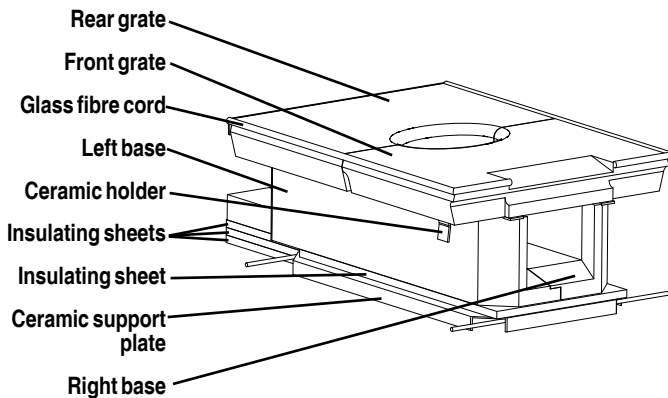

To prolong the service life of the ceramic:

- Limit the flue gas temperature to 250-300°C by closing the flue gas damper slightly or by installing turbulators in the flue gas pipes. Contact Värmebaronen for more information.
- Do not remove the ceramic when cleaning the boiler combustion chamber.
- Scrape the ceramic gently and carefully when removing ash from the boiler.
- Leave a couple of centimetres of ash as a protective layer on the grate.
- Only use "real" wood, avoiding plastic, treated timber or refuse.
- Place the wood in the boiler, do not throw it in.
- If the boiler/ceramic is new or if the boiler has not been used for a while, light a small fire to heat the ceramic and remove any moisture.

## Inner ash hatch

The diagram below shows how to insert the inner ash hatch. Follow the steps in reverse to remove it.

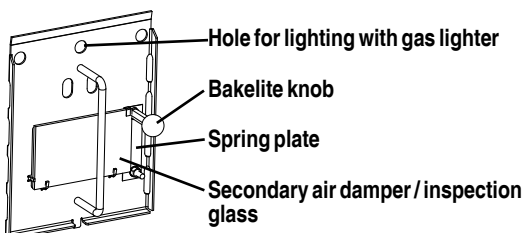
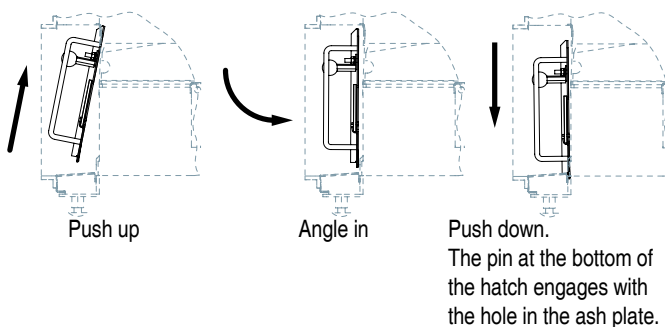

## Bypass damper

Only open the boiler's bypass damper when lighting the boiler or adding firewood, in order to prevent smoke entering the room. Otherwise, the damper must be kept closed.

## Flue gas damper

The flue gas damper is adjusted using a lever on the front of the boiler, and is used to control the flue gas temperature while firewood is being used. When pellets are being used, the damper is used together with the draught regulator to reduce the draught to a reasonable value.

## Controlling combustion

Combustion is controlled by the draught from the chimney, and by the addition of oxygen in primary air and secondary air, which is supplied through the draught hatch in the ash hatch.

An adjusting screw is used to control the opening of the draught hatch, and is normally set so that the draught hatch is fully open.

You can increase the supply of secondary air by turning the Bakelite knob for the secondary air hatch on the inner ash hatch. There should normally be an opening of a few millimetres along the top of the damper. The opening will have to be larger if the wood is damp or if the chimney draught is strong. The colour of the ash is an indicator of the effectiveness of combustion. The ash should be grey to light brown in colour.

To optimise combustion and efficiency, the flue gas temperature should be between 250- 300°C. If the temperature is too high, over 300°C, you can lower the temperature by restricting the flue gas damper or install turbulators in the boiler (accessory).

You must not use the draught hatch of the boiler to control the flue gas temperature. Closing the draught hatch restricts the supply of oxygen, impairing combustion.

## If there is a risk of freezing



**Never start a burning cycle if you suspect that any part of the heating system might be frozen. Call the installer.**

In severe cold weather, no part of the heating system should be turned off as this would involve a risk of burst pipes. If the heating system will be turned off for an extended period, the water should be drained.

## Draining the boiler

The boiler must not be running while it is being drained. Close the valves to the heating system. Run the water to a floor drain via a hose connected to the boiler drain valve, R15. Allow air into the system, for example by opening the boiler safety valve.

## Boiler cleaning

Keep the boiler clean and tidy. Alkaline cleaning agents are useful for removing soot marks from the boiler. Do not use strong solvents.

## Using electricity and firewood in combination

Using electricity and firewood in combination works very well. With an immersion heater in the accumulator tank, electric heating can take over when the temperature in the accumulator drops too low. You can use the electric thermostat to set the acceptable temperature from the point of view of comfort. A suitable temperature could be 45- 50°C, which guarantees that there is enough domestic hot water.

Make sure the boiler temperature does not get too high, 95°C during the burning cycle. This may trigger the overheating protection. You will then not be able to connect the immersion heater until the overheating protection has been reset.

## Firewood as a fuel

The Vedolux has a ceramic grate and afterburning chamber, and works on the principle of reverse combustion. If the boiler is correctly operated, it burns very effectively, with high efficiency and low emissions and environmental impact.

The function and output of the boiler depend on the way the firewood is split and on the firewood's type, size and moisture content.

Using firewood as a fuel is not simply about burning the wood – the quality of the wood, the chimney, the accumulation tank and the burning techniques used have a decisive effect on the result.

## Firewood

Always use dry firewood with a moisture content of 12-25 %. Firewood with a higher moisture content lowers the combustion temperature, produces more harmful emissions and reduces efficiency.

Hardwoods generally have a higher energy content than conifers. Only use untreated and clean timber.

Because of the high acidity of oak wood, it should not be used as a fuel for extended periods. Oak should be seasoned for more than three years before it is burned.

The wood must be the correct size for the combustion chamber, around 50 cm long and around 15 cm wide, allowing three blocks to fit the width of the grate.

To allow the wood to dry out, the tree must be felled at least one season in advance. An alternative method is to fell the tree in spring just after the leaves have come out. Then wait a few weeks before trimming and splitting the wood. During these weeks, the leaves wilt and draw out the moisture. After another few weeks of drying, the wood has 25-30 % moisture content.

After cutting, the wood must be split. The more it is split, the faster and easier it will dry. Fresh wood is easiest to split.

The wood must not be in direct contact with the ground, as this causes the wood to take on moisture. Ideally the wood should be kept under a roof, in a place where the sun and wind can help dry it. The best place for final drying is the boiler room, for 2-3 weeks before the wood is used. The moisture content after drying is around 20 %.

## Heat content

The heat content is the amount of heat that can be extracted by the boiler and transferred to the boiler water. Heat content should not be confused with energy content, which increases with the size of the block of wood. The heat content increases with the dryness of the block of wood, because less heat is wasted on drying the wood.

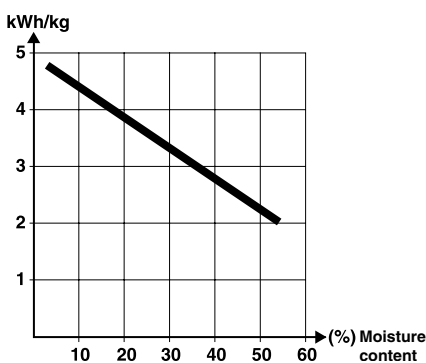

Newly cut wood has a moisture content of around 55 %. Firewood that has been dried out following our instructions has around 20 % moisture. The chart illustrates how the heat content changes.

If a building uses 25 m<sup>3</sup> of newly cut firewood (55 % moisture), around 14 m<sup>3</sup> of water needs to be dried through the chimney. The energy needed to vaporise 14 m<sup>3</sup> is wasted. Other problems using damp wood include poor combustion and dirty emissions, which in turn impair efficiency.

## First burning cycle

First check that the ceramic in the boiler firmly seated and has not moved during transport.

If the boiler is new or has not been used for a while, you should light the fire carefully so that any remaining moisture in the ceramic can vaporise slowly. Lighting a fierce fire may crack the ceramic. Only light a small fire the first time. Once the ceramic parts are dry, you can light a full-size fire. The ceramic does not take on moisture when the boiler is being used.

## Lighting a fire with the gas lighter

- Arrange a layer of medium size blocks of wood over some bunches of dry twigs, then fill the rest of the combustion chamber with large blocks.
- Close the firewood hatch and open the flue gas damper, keeping the bypass damper closed.
- Ignite the gas lighter and insert it into the nozzle in the hole at the top of the inner ash hatch. Move the flame from side to side, and the wood should have ignited after a minute.

## Lighting a fire without the gas lighter

- Place two small blocks of wood along the side of the grate, and lay some smaller twigs across them. On top of the twigs, place paper and more twigs.
- Open the flue gas and bypass dampers fully, and leave the ash hatch half open.

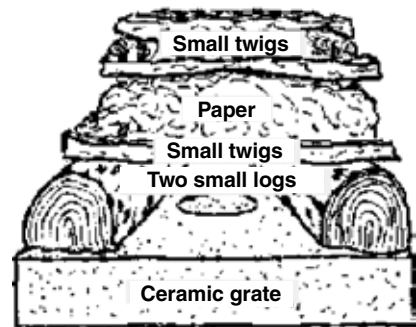

- Light the paper and close the firewood hatch.
- When the fire has caught and there is a good layer of embers, add more small blocks of wood to the combustion chamber first, followed by larger ones. Check the flue gas thermometer when the fire is lit – the temperature should be higher than 100°C. Fill up the combustion chamber, placing the firewood in line so that they fall down as the wood underneath burns.
- Fully open the draught hatch.
- Close the ash hatch and the bypass damper.

## Adding wood

Do not add any more wood until there is nothing left but an even layer of embers.

To make sure no smoke or flames enter the room, open the bypass damper before opening the firewood hatch.

Adjust the amount of firewood according to the temperatures in the accumulator system, to prevent overcharging.

Spread out the embers before adding new firewood. Then close the firewood hatch and the bypass damper.

When you add more firewood, stack the firewood carefully, positioning the logs so that they do not obstruct the hole on the grate.



**Constant "topping up" significantly lowers the combustion temperature.**

**Do not forget to close the bypass damper after adding firewood.**

The most common problems that occur when burning firewood are usually the result of the boiler failing to reach a high enough temperature so that the boiler never really gets going. Another common problem is that the heat is not transferred to the accumulator tanks even though the wood is burning well in the boiler.

<b>Poor combustion in the boiler.</b>	Poor draught in the chimney.	The required draught for the boiler is 20 Pa. Corrections are possible using a chimney fan. For chimney requirements, see the technical data.
	Damp wood.	A ceramic boiler requires a high combustion temperature. To achieve this, the wood must be dry, with a moisture content below 25 %.
	Incorrect handling.	Read the instructions and see the information video.
	The wood is not suitable for the boiler.	The firewood must be 50 cm long. The thickness should allow three to four blocks to fit the width of the grate.
	Shaped wood, rectangular wood.	If uniform blocks of wood are stacked on each other, a solid mass of wood is created with limited surface area for the fire to act on. Arrange the wood so there are gaps between the blocks.
	Fails to burn.	This happens when the wood is bent and is not suitable for the boiler. Use wood that is suitable for the boiler.
	Inadequate air supply.	The fresh air intake of the boiler room must have at least the same cross sectional area as the flue duct. Check that the air valve is open.
	Secondary air damper too open.	If the damper is too open, the primary and secondary air will be incorrectly distributed. You can increase the supply of secondary air by turning the Bakelite knob for the secondary air hatch on the inner ash hatch. There should normally be an opening of a few millimetres along the top of the damper. The opening will have to be larger if the wood is damp or if the chimney draught is strong. The colour of the ash is an indicator of the effectiveness of combustion. The ash should be grey to light brown in colour.
	Leaking flue connections.	The draught is crucial to efficient combustion. There must be no loss of draught because of connections that are not airtight. Make all connections airtight!
	The chimney runs downwards from the boiler connection.	The turbulence created takes away some of the draught. Fill the lower part with sand or similar material.
	Chimney situated in a cold place.	A chimney situated outside the building is more sensitive to weather and wind than a chimney inside the building. A chimney fan can help increase the flue gas temperature quickly and therefore improve the draught.
	No accumulator control.	A ceramic boiler is at its most efficient when the ceramic is hot. The temperature in the boiler therefore needs to be increased quickly before charging begins. Add a control system.
Ceramic not correctly positioned.	If the boiler is new, check that the ceramic has not moved during transport. Never remove the ceramic, even for cleaning. However, if it is removed anyway, make sure it is replaced correctly. Check the seal with the combustion chamber walls.	

<b>High flue gas temperature.</b>	Tar, soot in the pipes.	Due to incorrect combustion. Check the firewood, the draught, the air intake and the handling. Clean the boiler.
	Faulty flue gas thermometer.	The thermometer may have been damaged by cleaning or by long periods of updraught burning.

<b>Tar and large quantities of soot in the pipes.</b>	The boiler is working in updraught mode for too long.	When you light the boiler, you should fill it with enough kindling to produce the flames needed to change to reverse combustion after approx. 5 minutes.
	Incorrect combustion.	See High flue gas temperature.

<b>Heat is not transferred from the boiler to the accumulator.</b>	Wrong connections.	Check
	Circulation pump too small.	The pump must have sufficient capacity to transfer the heat. Change to a larger pump.
	Air.	If you make the connections as suggested, the system will not be sensitive to air problems. Vent.
	Wrong connection of accumulator.	See the points above.

<b>Boiling noises in the boiler.</b>	Low pressure head.	Check the pressure, which should be about 1 bar. The expansion vessel must be dimensioned for the volume and for the temperature variations that occur.
	High flue gas temperature.	A strong draught combined with dry wood will make the boiler operate outside its power range. Limit the flue gas temperature to a maximum of 300°C.

26	31 02 10	Front ceramic grate	1	23	38 00 20	Hydrothermometer, 1/2" x 90	1
27	31 02 11	Rear ceramic grate	1		38 00 30	Flue gas thermometer, M10 x 120 mm	1
28	31 02 12	Left ceramic base	1		44 02 27	Gas lighter handle	1
29	31 02 13	Right ceramic base	1		37 00 20	Cover plate, 14 x 50	2
30	30 00 07	Glass fibre cord 15 mm (m)	1.4		37 00 21	Cover plate, 25.4 x 65	1
31	808 28	Ceramic holder	1		37 00 22	Cover plate, 32.5 x 77	2
32	31 00 15	Insulating sheet, Keranap, 250 x 500 x 12	1		37 00 23	Cover plate, 39.5 x 77	3
33	31 00 18	Insulating sheet, Keranap, 204 x 175 x 12	3		37 00 24	Cover plate, 50 x 87	4
34	904 58	Ceramic support plate	1		37 00 60	Bakelite knob	1
	904 57	Base plate next to ash hatch	1	39	37 00 64	T handle	2
7	909 21	Cleaning hatch	1	40	23 00 74	Damper arm for flue gas damper	1
8	32 00 07	Firewood hatch	1		23 00 75	Damper arm for bypass damper	1
11	32 00 14	Draught hatch	1		23 00 76	Damper arm lock	2
35	10 09 04	Pole screw M5 x 40 mm	1		83 09 02	Bypass damper	1
	44 00 11	Spring steel shaft 1500 mm	1		83 24 74	Air duct for combustion chamber top	1
	44 00 02	Pipe cleaner 89 mm	1		835 37	Bypass damper pin	1
	44 00 05	Pipe cleaner 595 x 80 x 60/30 mm	1		836 64	Air plate support	1
	904 56	Ash rake	1		24 03 50	Drain valve 905-R15 ext	1
19	70 02 56	Cleaning tool bracket	1	3	903 51	Flue pipe, complete	1
	904 54	Inner ash hatch, complete	1	20	10 01 13	Wingnut	2
12	37 00 60	Bakelite knob 25 mm	1	41	30 00 32	Gasket for cleaning hatch	1
36	44 01 91	Inspection glass	1	42	30 00 33	Gasket for flue pipe	1
37	71 00 14	Spring plate	1				
38							

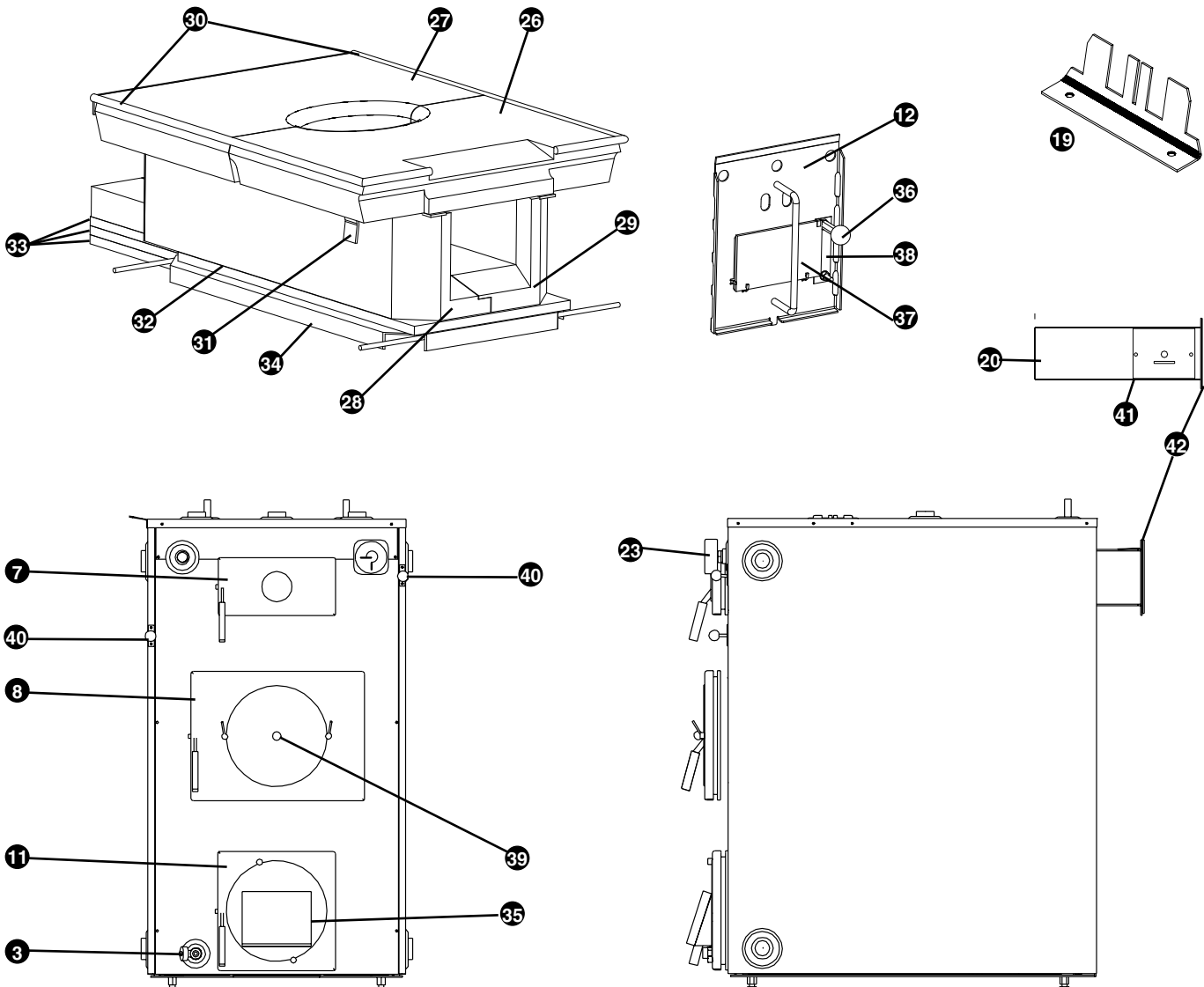







Värmebaronen AB retains the right to change the specification of included components without prior notice, as part of its policy of continuous improvement and development.

Värmebaronen AB  
Arkelstorpsvägen 88  
291 94 Kristianstad  
Sweden

T +4644-226320  
F +4644-226358  
[www.varmebaronen.se](http://www.varmebaronen.se)  
[info@varmebaronen.se](mailto:info@varmebaronen.se)

